

X90-T

WHEEL EXCAVATOR

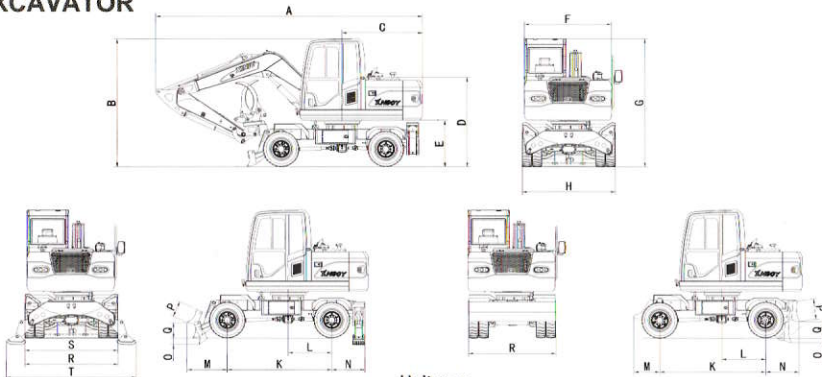

Unit :mm

MAIN DIMENSION

	Front dozer blade /rear outrigger	Rear dozer blade
A Total length		
Boom3.3m+Bucket arm 1.75m	XN90-Y-A 6102	XN90-Y-B 6102
Boom3.5m+Bucket arm 2.00m	XN90-Y-C 6266	XN90-Y-D 6266
B Total Height		
Boom3.3m+Bucket arm 1.75m	XN90-Y-A 2932	XN90-Y-B 2932
Boom3.5m+Bucket arm 2.00m	XN90-Y-C 2932	XN90-Y-D 2932
C Counter weight turning radius	1836	1836
D Hood Height	2054	2054
E Counterweight Ground Clearance	1070	1070
F Upper structure width	2000	2000
G Cab Height	2932	2932
H Total Tire Width	2130	1990
J Minimum Ground Clearance	285	285
K Wheel Tread	2400	2400
L Distance of swing center to rear wheel	1000	1000
M Front Extension	920	590
N Back Extension	754	764
O The maximum reduction of the dozer blade	150	100
P Height of dozer blade	360	470
Q Maximum lift of dozer	300	390
R Overall width of blade	2138	2000
S Total width with outrigger back	2130	
T Total width with outrigger out	2965	

OPERATING RANGE

Working device	Boom3.3m+Bucket arm 1.75m	Boom3.5m+Bucket arm 2.00m
A Maximum grab radius	5808	6272
B Maximum unloading height	4677	4972
C Maximum grab depth	3376	3789
D Minimum radius of gyration	2177	2334

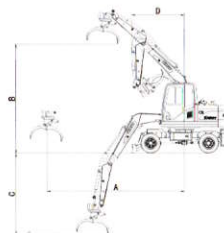

SPECIFICATION Unit

	Operating weight	7680 kg
	Bucket capacity	0.3 m ³
	Model	Yanmar 4TNV98-ZCSLK
Engine	Displacement	3.319L
	Rated power / speed	44kW /2200 rpm
Speed	Max. torque	223.3~243.5N.m/1600±100rpm
	Max.travel speed	28 km/h
	Swing speed	12 rpm
Hydraulic and liquid capacity	Max. grade ability	30°
	Pump type	Variable X1
	Pressure P1、P2	25 MPa
	Flow rate P1、P2	132 L/min
	Hydraulic tank capacity	175 L
Fuel tank capacity	150 L	
Engine fuel tank capacity	12 L	

X90-T WHEEL EXCAVATOR

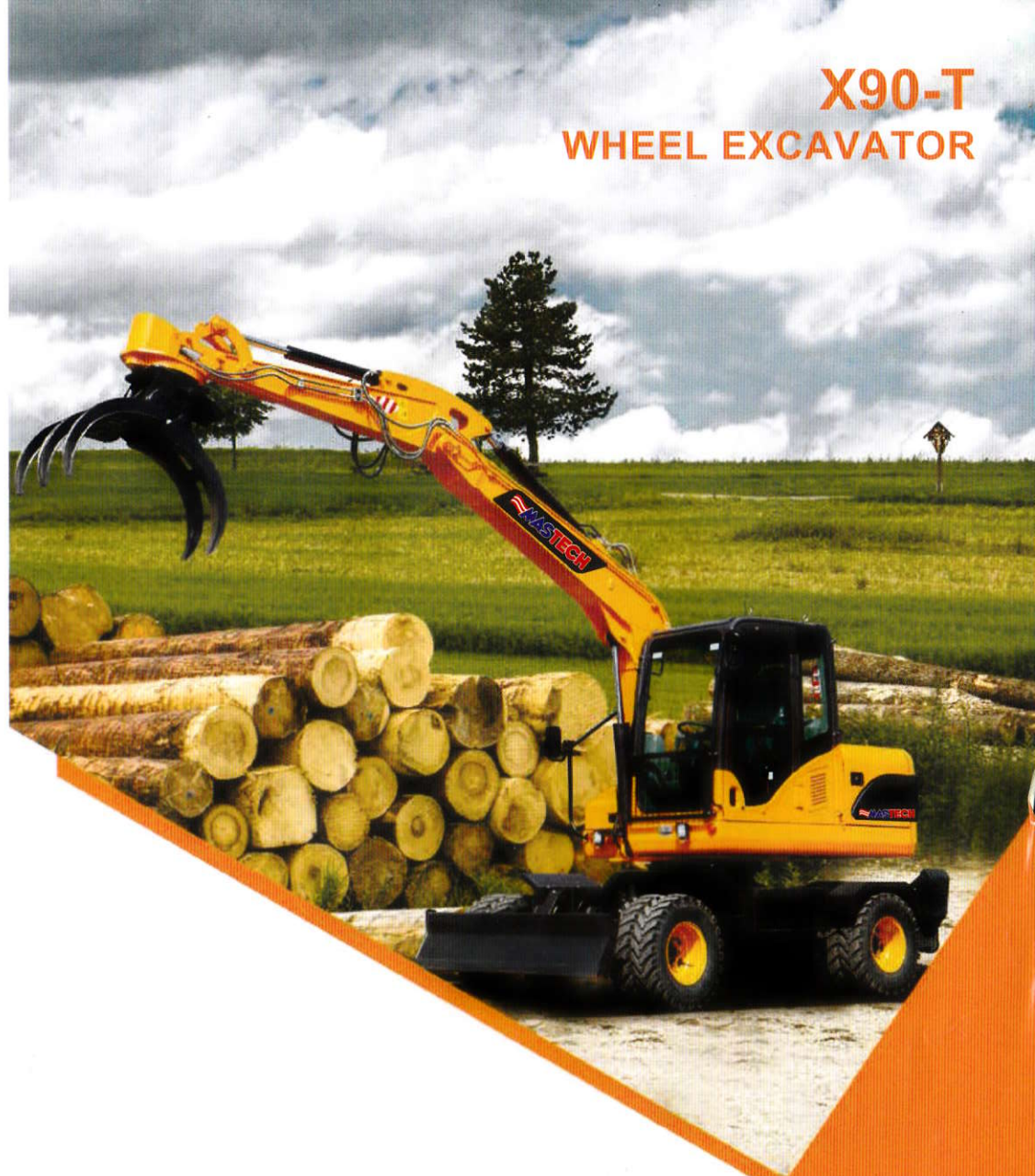



X90-T WHEEL EXCAVATOR

CE ISO TUV
Chinese Well-known Trademark



New upgrade cabin, beautiful out-looking, cabin ergonomic design, front gear institutions, adjustable suspension seats, air conditioner, large-screen LCD display, open field of vision, Operating more comfortable.

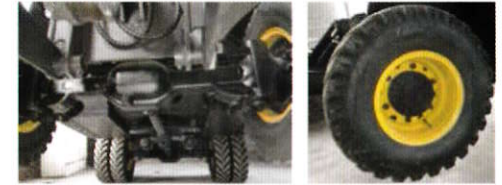

The overall box-type structure chassis, with reinforced front and rear driven axles, reinforcement gearbox, reinforcement up and down box, more load carry capacity. Front and rear driven axles with hub reduction, more passing ability, suitable for complex road, more driving power, suitable for climbing.



Parataxis radiator, full steel mesh back door, increase ventilation, improving the cooling efficiency, the back lights hidden inside the counterweight completely, avoiding the collision at the complex conditions working.

More power, low oil consumption.

Japan import engine
Seek green emission and high-power output Yanmar TNV
Direct injection diesel engine.
Improve the oil injection system, meet to exhaust gas emission
in lots countries, low noise can be good for the health and
environmental protection

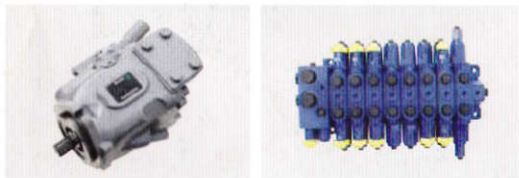

Branded International brand plunger pump, main valve, quick moving, compound movement harmoniously, high reliability, long service time.

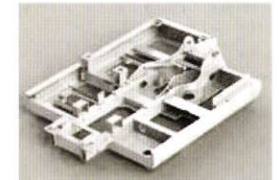

The upper structure and working device is under finite element analysis, better structure, improve the strength and tenacity of upper structure and working devices.